

## M6410C/L M7410C

### SMALL 3-POSITION LINEAR VALVE ACTUATORS

#### PRODUCT DATA

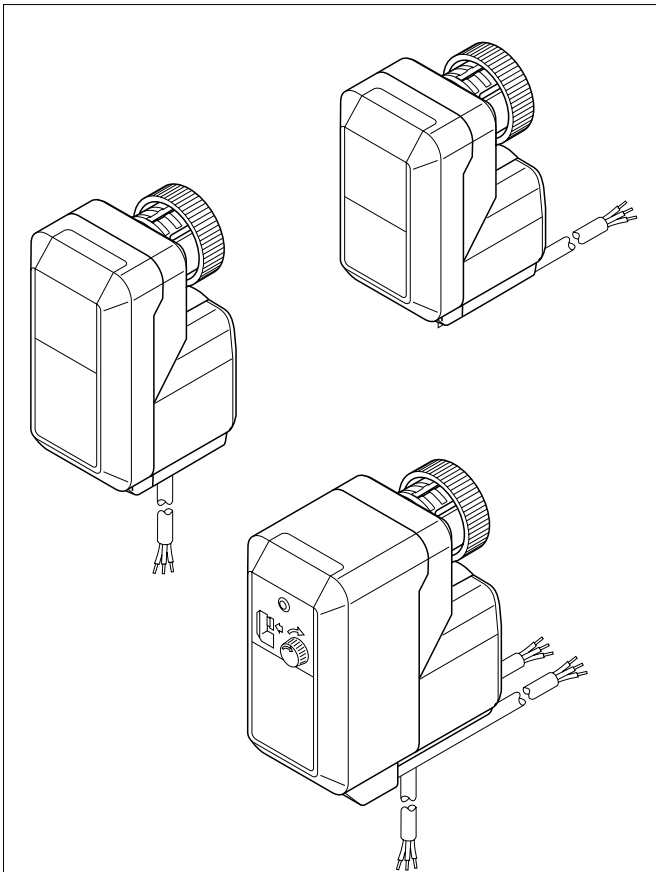

#### APPLICATION

The Honeywell M6410C/L and M7410C actuators are specifically designed to provide floating control together with the V5822/23 and V5832/33 series of small linear valves.

The M6410C/L and M7410C actuators are used in fan-coil-units, induction units, small reheaters and recoolers and for zone control applications. They are employed in electronic temperature control systems using hot and/or cold water as the controlled medium.

The M6410C/L and M7410C actuators are suitable for Honeywell Excel series controllers as well as for Honeywell individual room temperature controllers. These controllers track the precise valve position by counting the number of individual control pulses which move the valve from one position to another. For this reason, the actuators do not need endswitches or a feedback potentiometer. The absence of these mechanical components ensures longtime reliability.

The M6410C/L and M7410C actuators are also compatible with any controller providing intelligent position control and having a built-in shut-off function.

These actuators are well suited for applications where space is limited and minimum power consumption is required. The actuators are both attractive and robust in design.

#### FEATURES

- Small size allows installation where space is limited
- Low power consumption
- Reliable longtime operation because mechanical feedback potentiometers and mechanical endswitches are not required
- Magnetic coupling for stem force limitation and self-adjustment of the close-off-point
- Reversible synchronous AC motor
- Suitable for three-position modulating control without proportional feedback
- Supplied with prewired connection cable
- Simple, standardized valve/actuator coupling  
No tools required for mounting
- Visual valve position indicator furnished with actuators
- Manual operation provided by the valve adjustment cap, extra knob, or with a hexagon key
- Auxiliary switch

## SPECIFICATIONS

### Motor

Input voltage:	24 Vac +10 % ...-30 %; 50/60 Hz 230 Vac +10 % ...-30 %; 50/60 Hz
Power consumption:	0.7 VA
Control mode:	floating
Stroke:	6.5 mm
Running time:	150 s at 50 Hz 125 s at 60 Hz
Stem force:	depending on version (see table)
Protection standard	IP 43 in accordance with EN 60529
Insulation class (acc. EN 60730):	II/III depending on type
Connection cables:	1.5 m
Ambient operating temperature limits:	0 ... 60 °C
Weight:	0,4 kg
Suitable valves:	see table
Manual operation:	see table

### Auxiliary Switches

Ratings:	5 V ... 24 V max. 100 mA 24 Vac ... 230 Vac max. 3(1)A	
Switch position (factory supplied):	S1 (fix)	17.8 ± 0.2 mm
	S2 (adjustable)	11.7 ± 0.2 mm

## OPERATION

The movement of the electric actuators is produced by a screw spindle which is driven in both directions by a synchronous motor through a set of gears. A magnetic clutch limits the torque of the gear assembly and the driving force of the actuators. The actuators are fixed to the valve body by means of a coupling ring requiring no tools for mounting. The actuators are maintenance-free and supplied completely with a ready-to-wire connecting cable.

## VERSIONS

	Power supply	Manual operation	Stem force	Aux. switch S1	Aux. switch S2	Housing type	OS number
Standard	24 Vac	Provided by the valve adjustment cap	180 N	–	–	A	M7410C1007
	24 Vac		300 N	–	–	B	M7410C1015
With manual operation	24 Vac	Integrated	180 N	–	–	C	M6410C2023
	24 Vac	"	300 N	–	–	C	M6410C2031
	230 Vac	"	180 N	–	–	C	M6410L2023
	230 Vac	"	300 N	–	–	C	M6410L2031
With manual operation and auxiliary switches	24 Vac	Integrated	180 N	x	–	C	M6410C3021
	24 Vac	"	180 N	x	x	C	M6410C4029
	24 Vac	"	300 N	x	x	C	M6410C4037
	230 Vac	"	180 N	x	x	C	M6410L4029
	230 Vac	"	300 N	x	x	C	M6410L4037
Special versions	Bulkpack, 25 actuators incl. 1 manual						On special request
	Special cable length length = XX m						On special request

## MOUNTING POSITION

The actuator may only be mounted beside or above the valve. Adjust the valve in the right position before mounting the actuator.

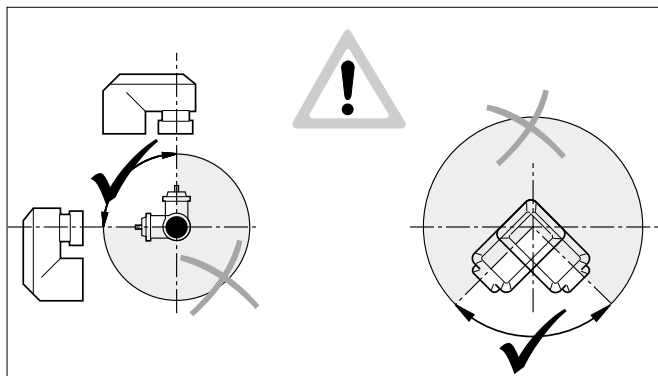

Fig. 1 Mounting positions

## MOUNTING

Before the actuator is fixed to the valve, the adjustment cap must be removed (Fig. 2). Make sure that the actuator is in the retract position (factory supplied position) before fixing the actuator to the valve body.

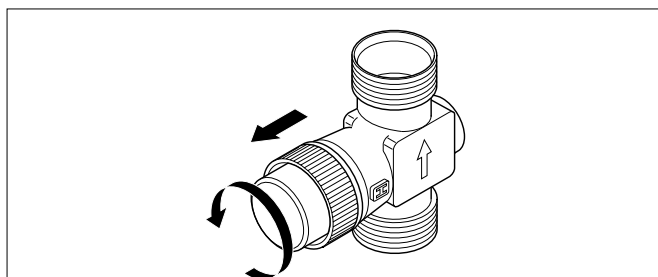

Fig. 2 Remove protection cap

The actuator must be mounted by hand. Don't use tools or additional force because actuator and valve may be damaged.

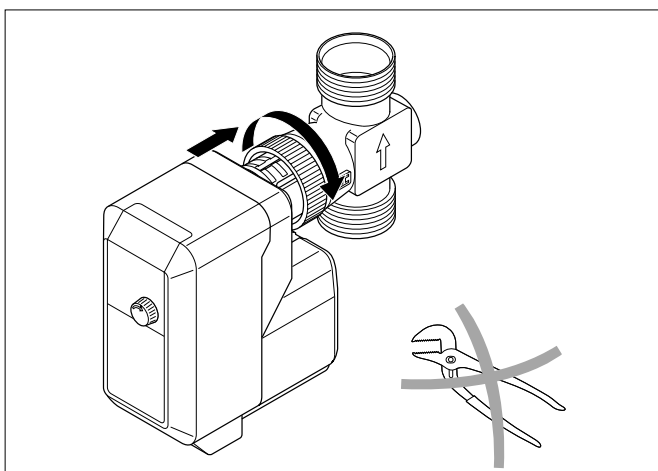

Fig. 3 Mounting the actuator

## ELECTRIC WIRING OF MOTOR

A fuse with a contact gap of at least 3 mm for each pole must be fitted with the fixed installation. The fuse rate is max. 2 A.

The electrical installation must comply with the wiring diagram shown in Fig. 4.

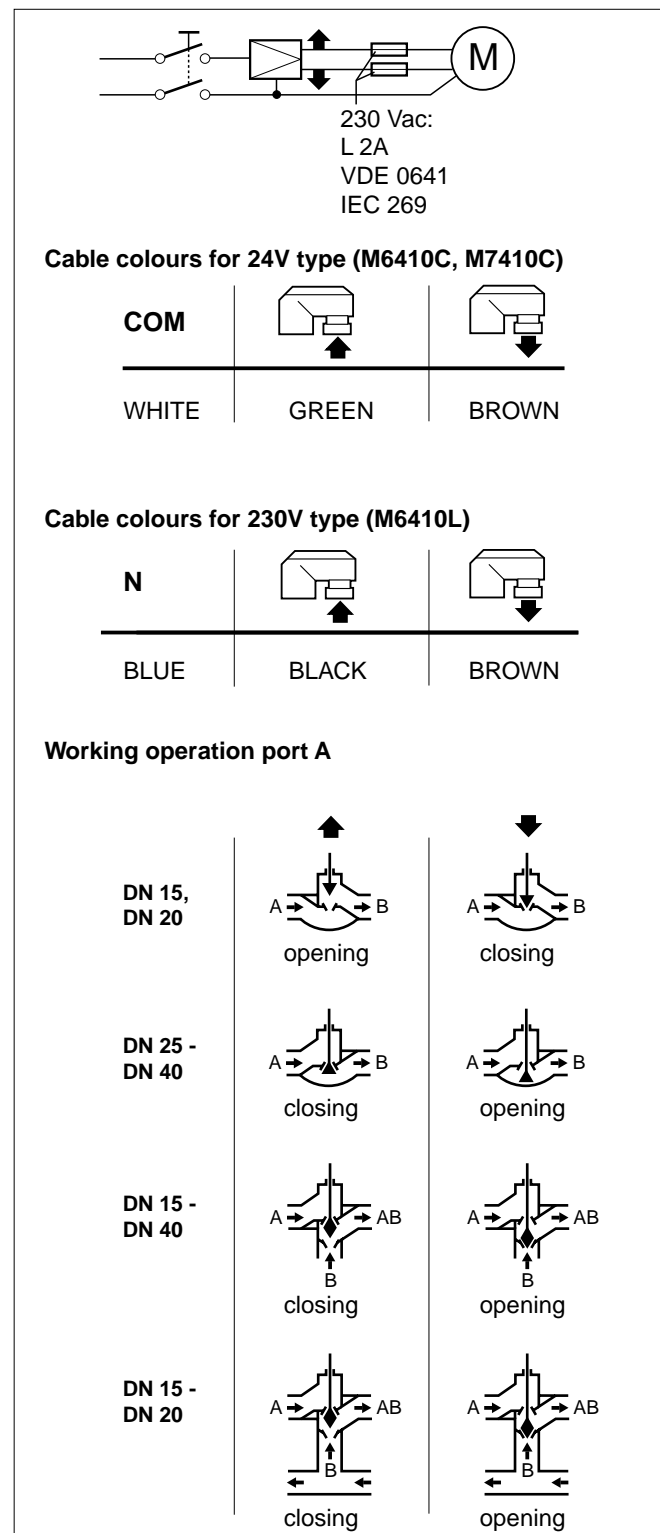

Fig. 4 Electric wiring of motor

## MANUAL OPERATION

The actuators with integrated manual operation (see table "Versions") are featured with a hexagonal key hole for manual operation. For more comfort an additional knob for the manual adjustment is packed separately. To prevent the valve from damage, the operation must only be done when there is no power applied to the motor.

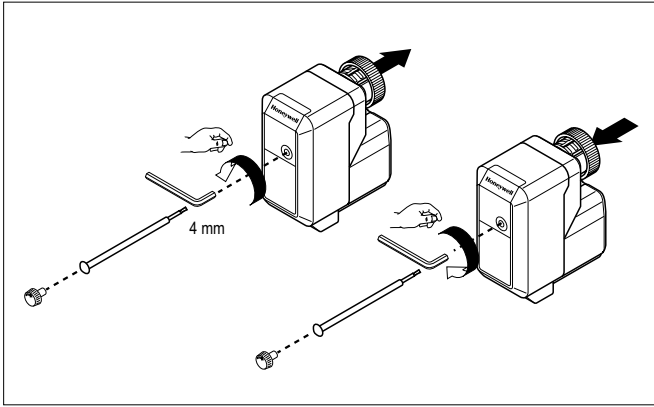

Fig. 5 Manual operation

## COMMISSIONING ADVICE

A functional check of the valve actuator can be carried out by changing the controller setpoint by 5 °C or more. The movement of the actuator stem (Fig. 6) indicates whether the valve is opening or closing.

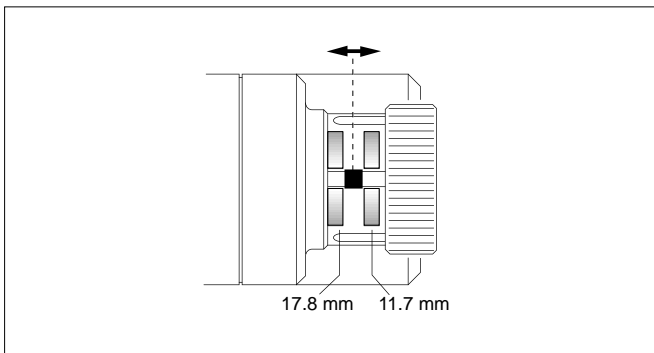

Fig. 6 Movement of the actuator stem

## AUXILIARY SWITCHES

The actuators with the OS-number M\*\*\*\*40\*\* are featured with 2 auxiliary switches. Each switch has its own cable. Auxiliary switch S1 with fix switchpoint when the stem position is in. Auxiliary switch S2 with adjustable switchpoint when the stem position is out.

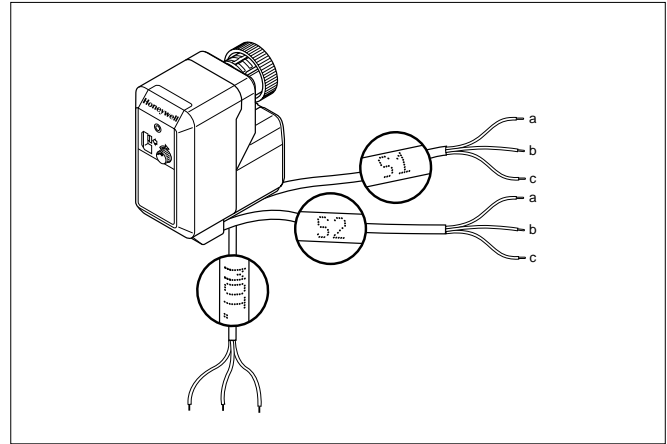

Fig. 7 Auxiliary switch cables

## Adjustment of Auxiliary Switch 2

The auxiliary switch 2 should be adjusted by a skilled person only.

Move the actuator to the position where the switch is to be operated. Cut the plastic skin with a sharp knife. Below the skin the adjustment screw can be accessed. Turn the screw clockwise until the end stop is reached. Turn the screw counterclockwise until the switch point is achieved. To check the required position has been set, move the actuator. Finally seal the adjustment hole with a piece of tape.

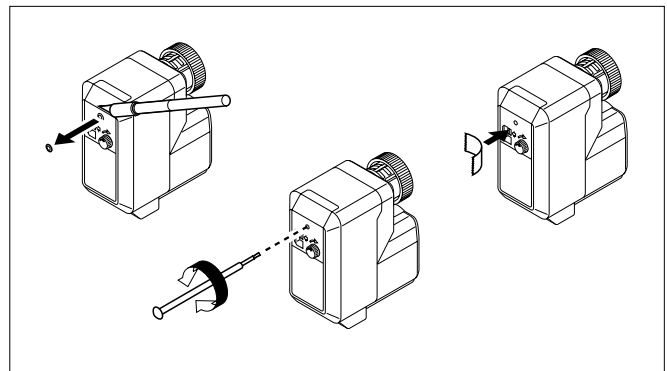

Fig. 8 Adjustment of auxiliary switch S2

## Electric Wiring of Auxiliary Switches

The electrical installation must comply with the wiring diagram shown in Fig. 9. If the auxiliary switch is connected to 230 Vac, a switch with a contact gap of at least 3 mm for each pole must be fitted with the installation.

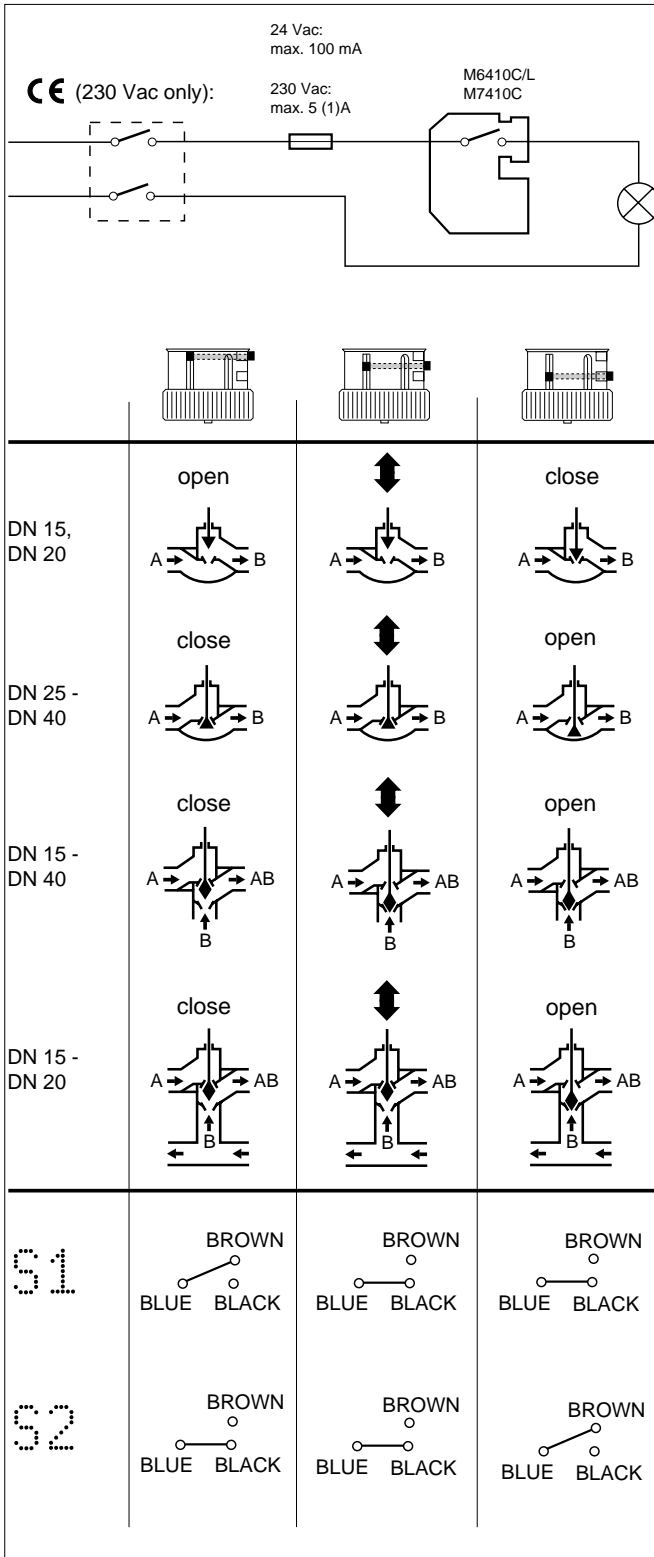

Fig. 9 Electric wiring of auxiliary switch

## Application Example: Switch off electrical Appliance

### 2-Way-Valve

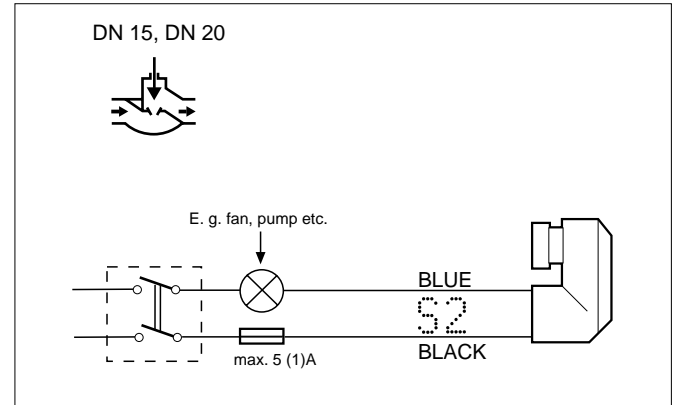

Fig. 10 Application example of auxiliary switch

### All other Valves

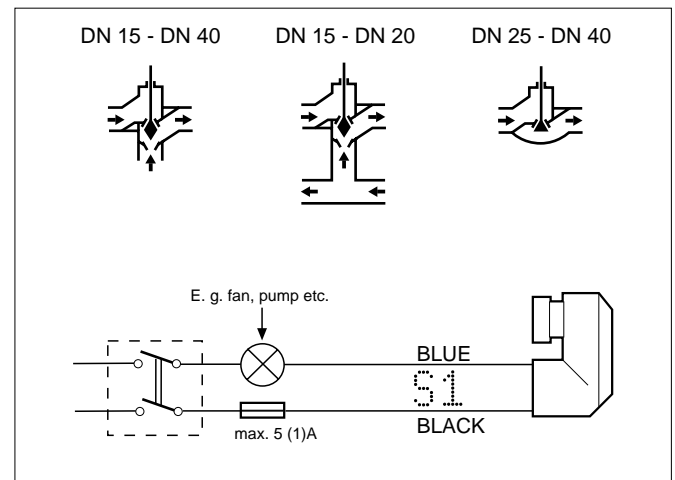

Fig. 11 Application example of auxiliary switch

## DIMENSIONS (MM)

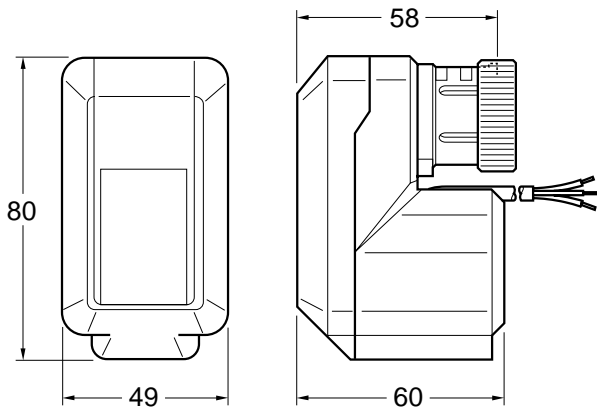

Fig. 12 Housing type A

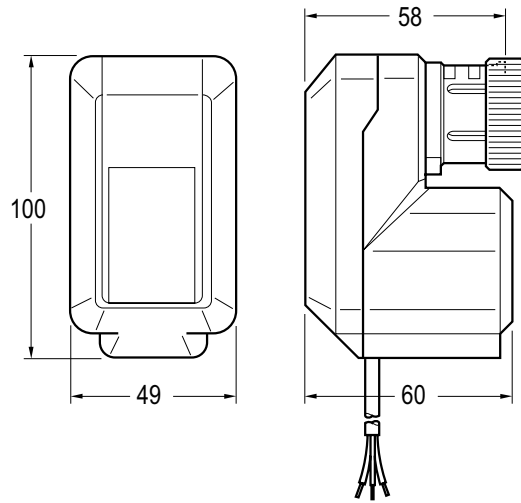

Fig. 13 Housing type B

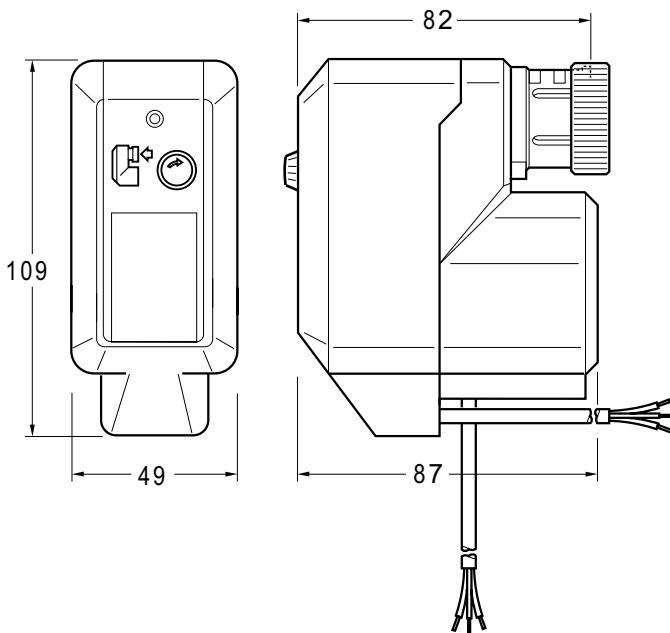

Fig. 14 Housing type C

**Honeywell**

### Home and Building Control Products

Honeywell AG  
Böblinger Straße 17  
D-71101 Schönaich  
Phone (49-7031) 637-01  
Fax (49-7031) 637-493  
<http://europe.hbc.honeywell.com>

Subject to change without notice. Printed in Germany.



Manufacturing location is certified to **DIN EN ISO 9001**

EN0B-096GE51 R0399